

1. Measure & setup

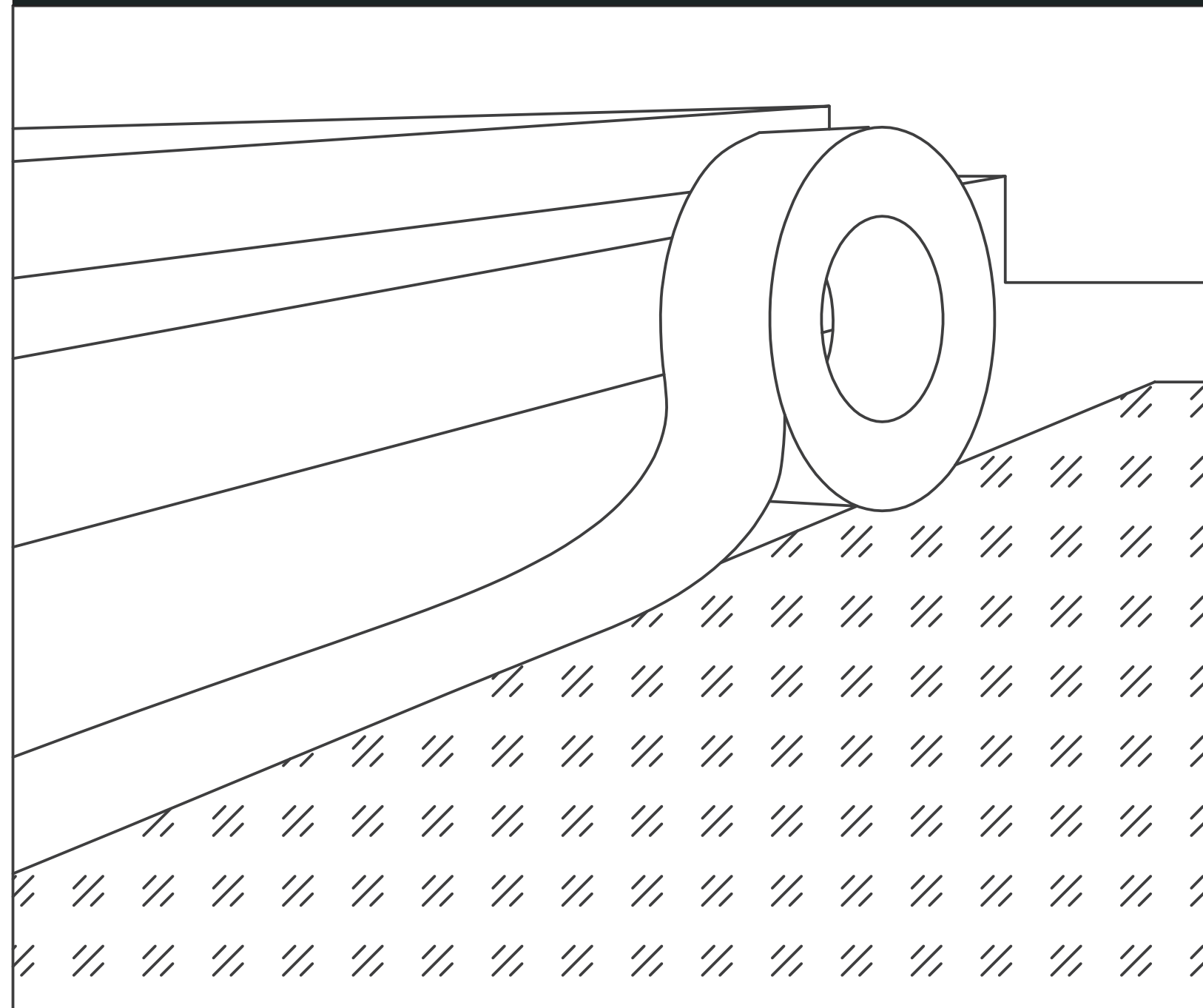

Measure layout in compliance with AS/NZS 1428.1 Standards. In Most Occasion is 300mm setback.

Align installation template to marked layout

Tap template down with masking tape on all edge.

4. Applied Adhesive

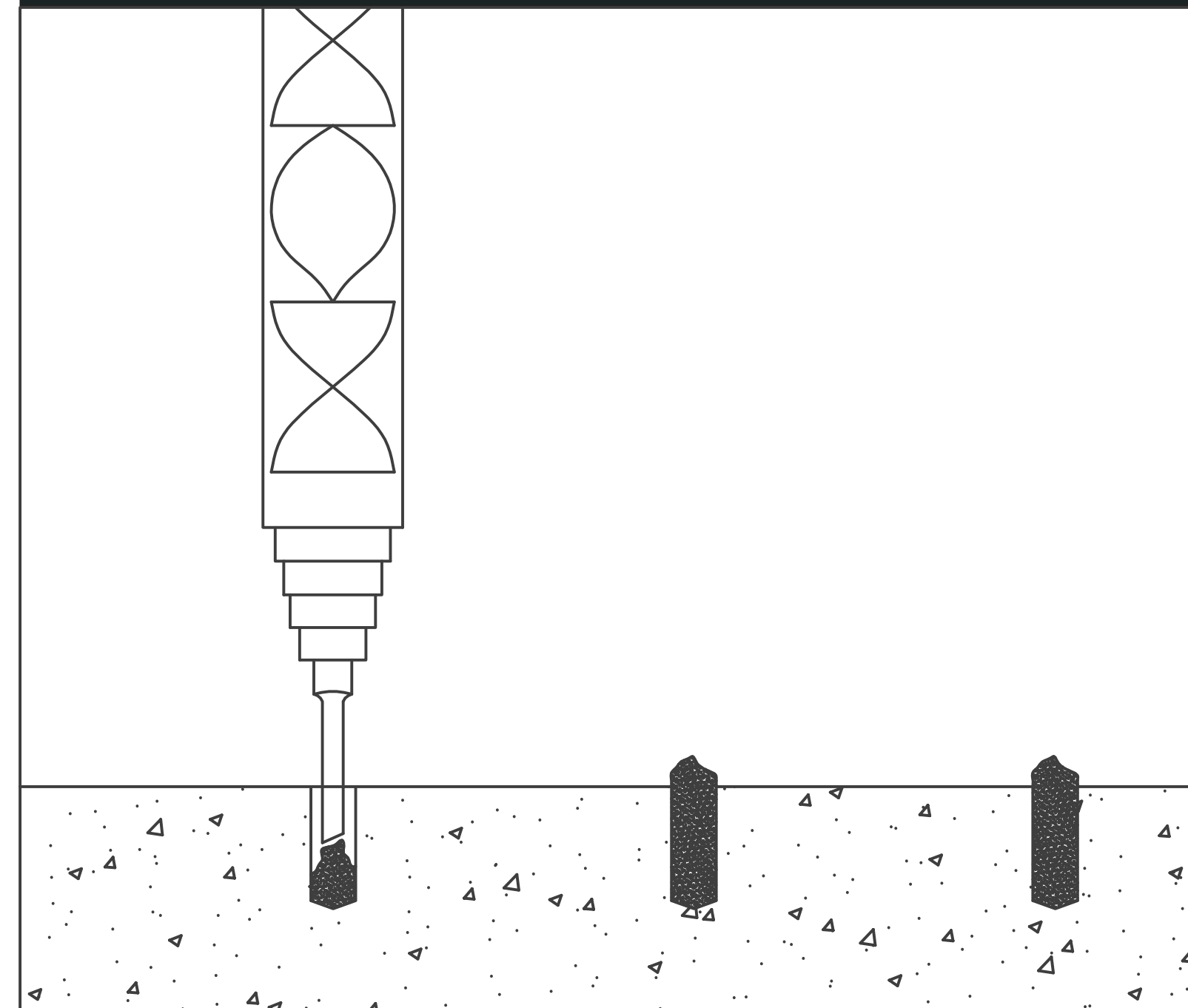

Inject adhesive into each hole

Do not overfill

Tips: Approximate 1lm (600mmx 1000mm)per 310ml bottle.

2. Drilling

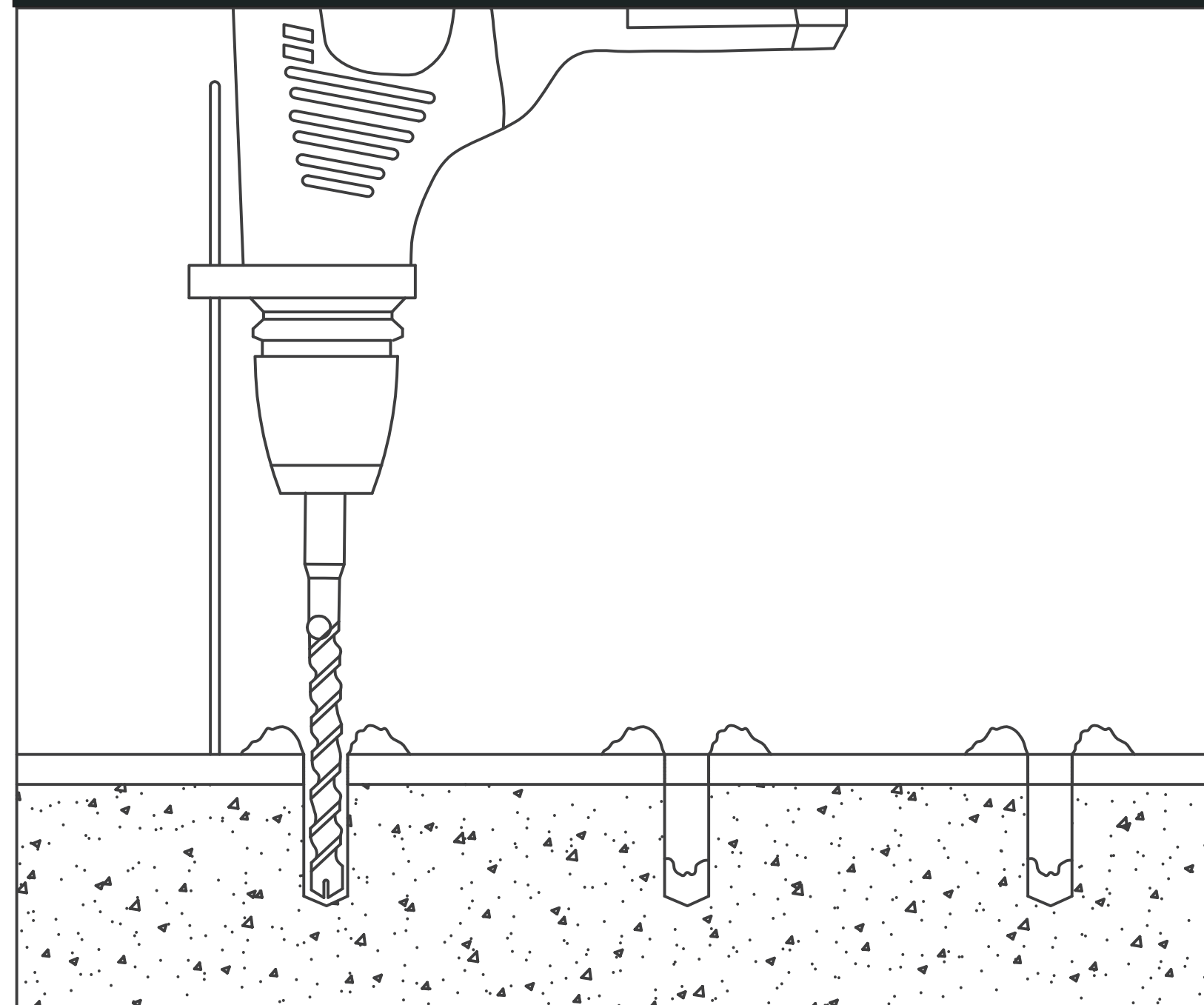

Set drilling guage to 20mm

Drill holes with 7mm drill bit

- SDS drill bit is recommend for most concrete surface

- Some tile surface requires diamond drill bit

5. Fitting Tactile

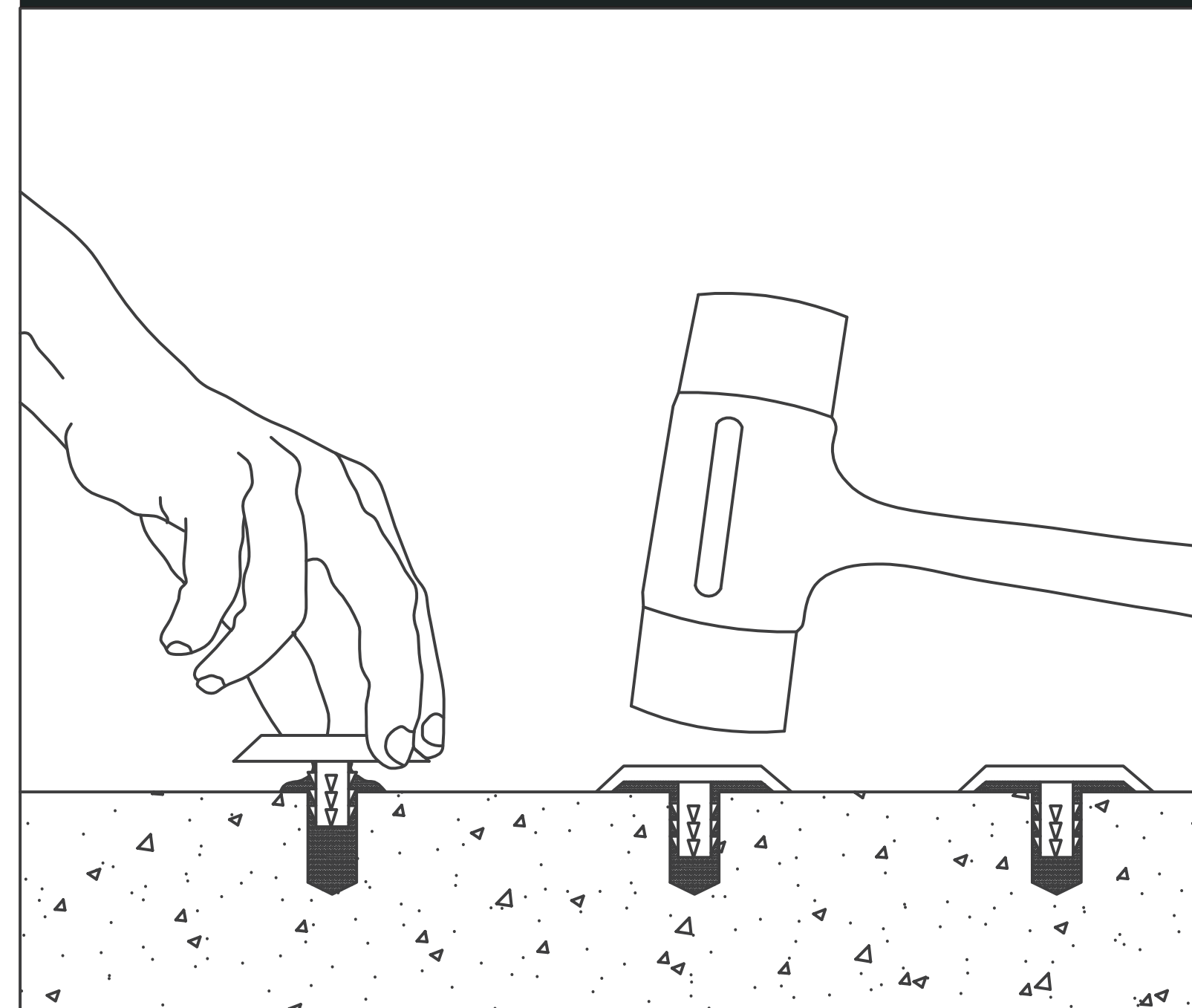

Push Tactile in each hole with a mallet

Ensure each tactile fit flat on surface

wipe off any excess adhesive

Adhesive will be set within 60min and ready to accept heavy traffic

3. Remove Dust

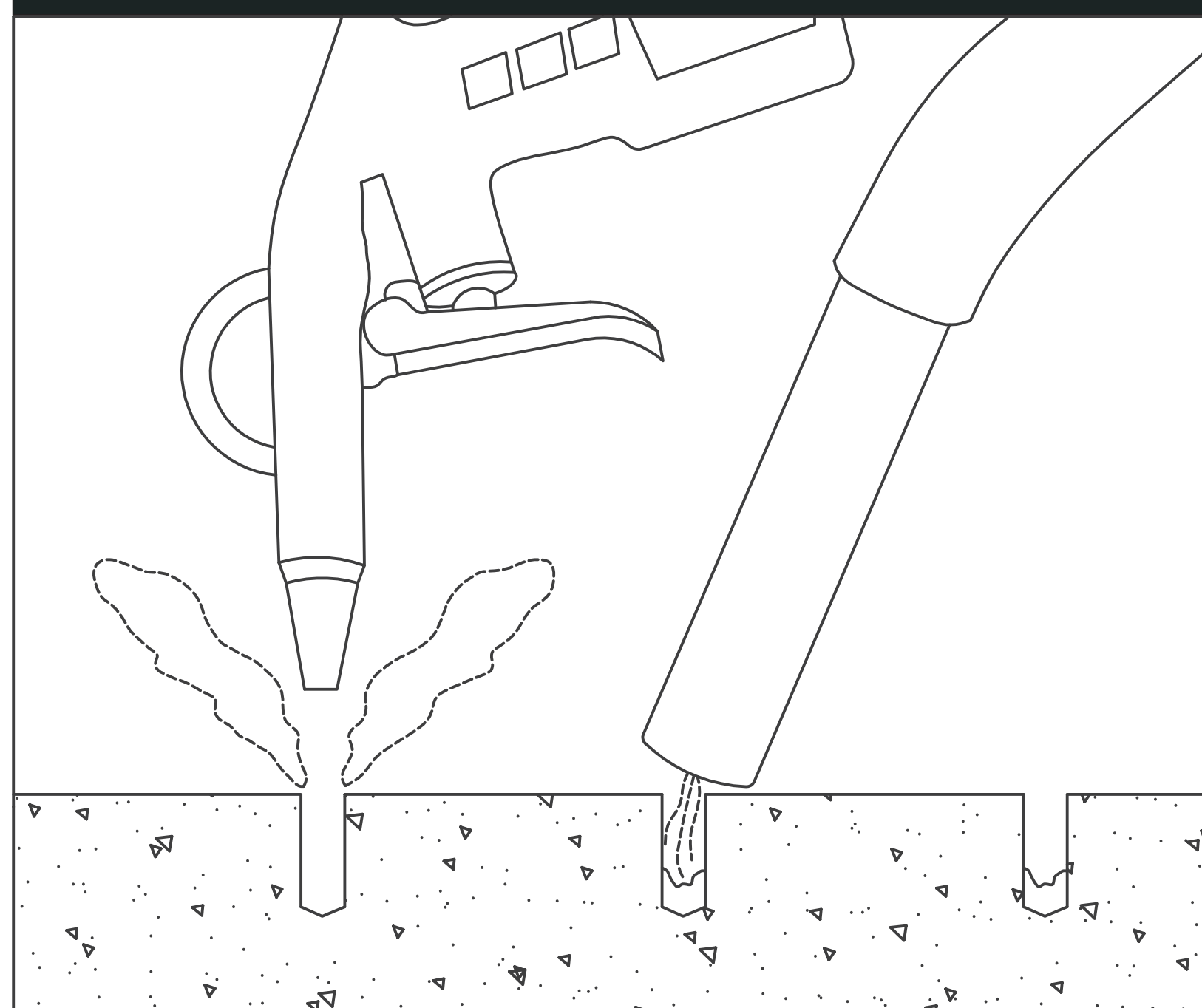

Remove installation template

Vacuum and blow out substrate dust

Clean all surface before applying adhesive

Need More Advice ?

Contact 02 9790 2182 and tell us about your project,
Our expert team will be able to provide you the best solution.